



PVE Enclosed Body Valves

For Demanding Duties

EXPLODED VIEW OF PVE VALVE WITH MANUAL ACTUATOR

Part	Description	Part	Description	Part	Description
1	Upper body half	11	Center guide bushing	20	Thrust washer
2	Lower body half	12	Fixing plate for opening tags	21	Thrust bearing
3	Lower pinch bar	13	Allen screw countersunk	22	Stem
4	Upper pinch bar	14	Locking screw	23	Nut bushing
5	Sleeve	15	Seal strip	24	Pipe bushing
6	Hex nut	16	Grease nipple	25	Guide bushing
7	Hex screw	17	Retaining ring	26	Attachment frame
8	Washer	18	Key	27	Indicator pin
9	Side guide bushing, upper	19	Hand wheel	28	Hex nut
10	Side guide bushing, lower			29	Bottom plug

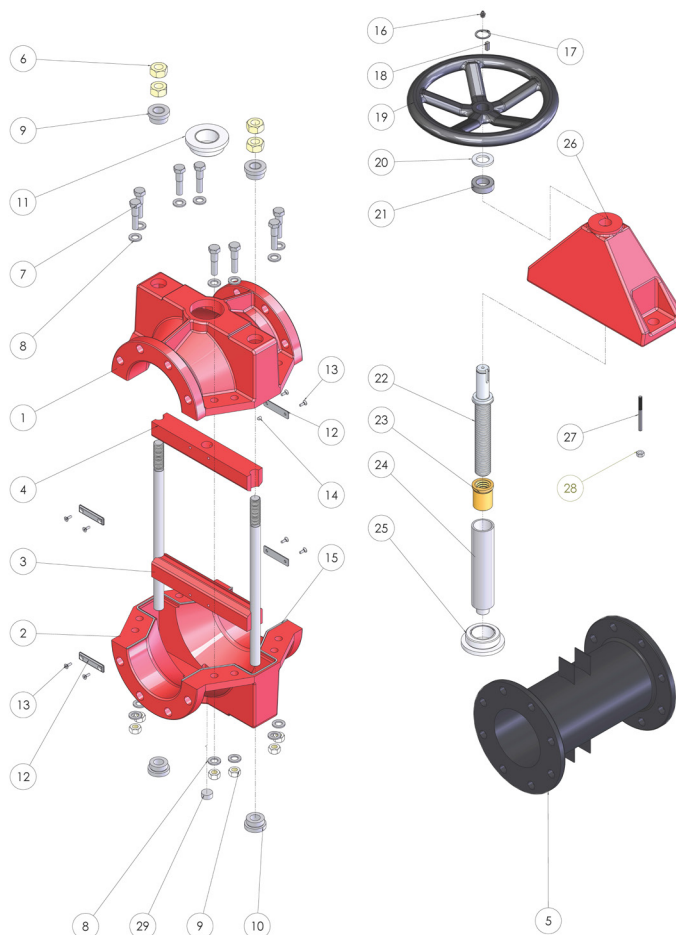

TECHNICAL DATA

- For heavy duty applications
- Body materials: Fe & AISI316
- Sizes beginning from 25 mm
- Pressure class up to 100 bar





MAIN DIMENSIONS OF PVE ENCLOSED BODY VALVES

MANUAL

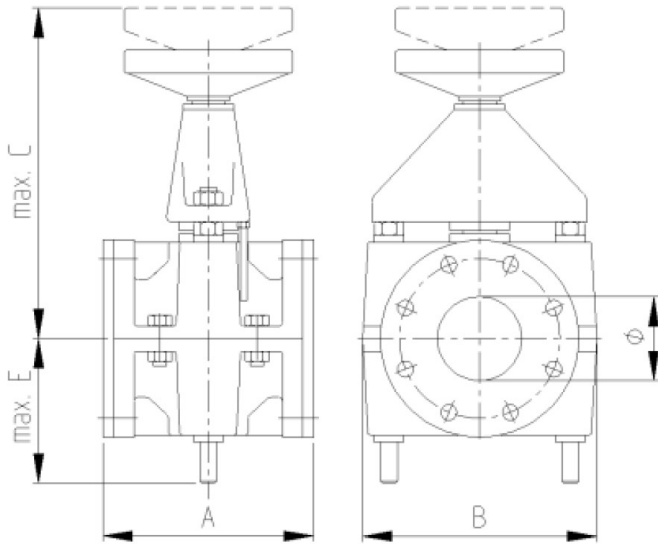

AUTOMATIC

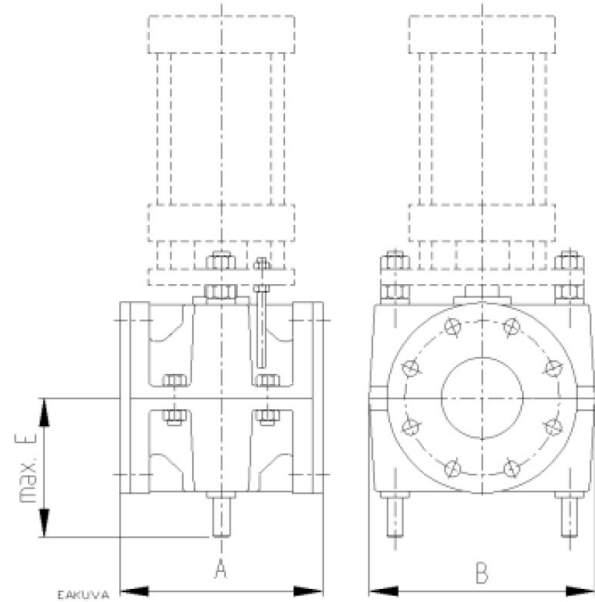

Valve size (PVE) M&A	PN (bar)	A	B	C	E	Weight Manual Valves (kg)		Weight Automatic valves (kg)	
						FE	AL	FE	AL
25	1-25	165	125	255	87	11	7	8	4
32	1-25	165	140	260	90	14	9	10	5
40	1-25	165	180	265	105	16	9	12	6
50	1-25	165	190	280	120	18	9	13	7
65	1-25	165	210	310	136	22	12	17	9
80	1-25	200	245	370	155	36	17	27	13
100	1-25	250	278	410	175	46	25	33	17
125	1-25	310	340	465	210	74	41	48	25
150	1-16	375	400	560	240	106	74	75	43
200	1-10	500	480	690	295	159	-	119	-
250	1-6	625	570	865	380	213	-	161	-
300	1	750	720	1020	445	279	-	212	-

Bigger sizes and higher pressures on request. All dimensions in mm.

Information without engagement. All rights to changes without prior notice reserved.



Flowrox Oy
P.O. Box 338, FI-53101 Lappeenranta
Finland
Tel. +358 201 113 311

www.flowrox.com
info@flowrox.com

